

Corrector concept for FFA arcs
Jay Benesch
8 August 2022

Requirement

While the permanent magnets making up the FFA proper will be shimmed to 0.01% accuracy, they cannot be installed with that accuracy. Correctors are therefore required to close both orbit and lattice. Since the permanent magnets occupy almost 90% of the arc, the correctors must be placed outside them. This is possible because permanent magnets are transparent to externally applied fields below their demagnetization point. This was done for CBeta. Stephen Brooks of BNL provided requirements by email:

The main reason for dipole (horizontal and vertical) correction is misplacements of magnets when installed.

+/-0.25mm is a reasonable assumption for the alignment errors after survey into place. Suppose the largest gradient in any FFA magnet we're considering is 60 T/m. Then the dipole corrector field should be

$$0.25\text{mm} * 60 \text{ T/m} = 15\text{mT} = 150 \text{ Gauss}$$

In CBETA, I remember we actually managed more than this, about 300 Gauss. This headroom is useful in case we need to do multi-orbit correction (send different orbits in different directions).

The quad correction will be set by magnet quad errors and temperature variation. Suppose we correct the quads to +/-0.1% gradient during tuning (I've done this here in my office, CBETA managed +/-0.05 but with easier magnets). Then, the gradient correction required for that is

$$0.1\% * 60 \text{ T/m} = 60 \text{ mT/m}$$

You'll also have a temperature coefficient of around 0.1% per degree(C), so may want to provide 2x or 3x this value in case the temperature is off by a degree for some reason.

Looking at the lattice and the scale drawings of the BD and BF magnets, a 20 cm square clear bore within a 40 cm long steel frame was chosen. The length should allow the permanent magnet support and alignment fixtures to protrude at each end so as to achieve the 0.25 mm alignment tolerance. The 20 cm square should allow for a box beam to support the permanent magnet and cooling provisions for the synchrotron radiation on the outer wall of the vacuum vessel. Detailed engineering is required to refine these dimensions but they are in the ballpark.

Conductor choice

The design was done assuming #14 square copper conductor. At the end of the process it was determined that this is not compatible with the existing 75V/20A trim supplies and should be changed to #11 square. The models shown were NOT revised to match the change in conductor. The fields will not change as they are determined by amp-turns (AT) and the steel. The revised coil parameters are discussed at the end.

Design

8/Aug/2022 06:43:50

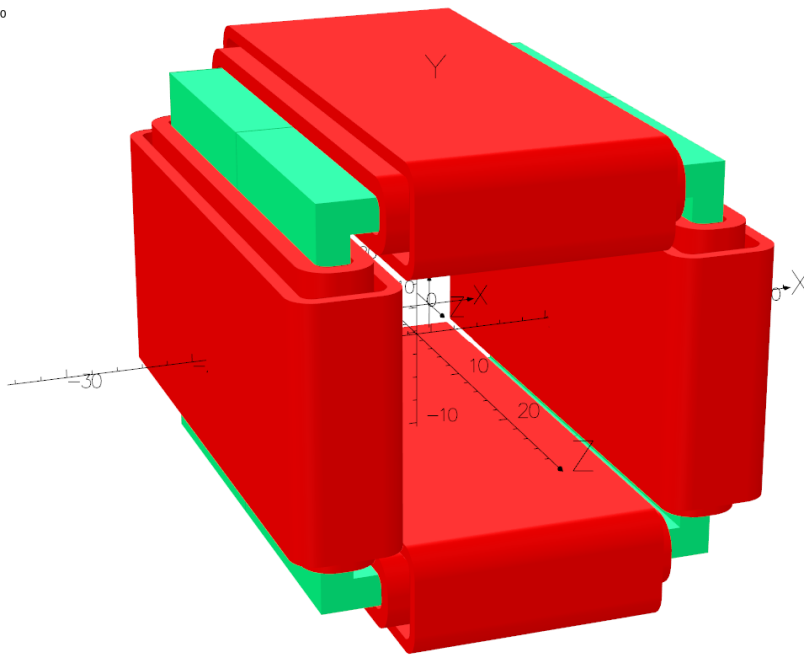

| UNITS | |
|-------------------|-------------------|
| Length | cm |
| Magn Flux Density | gauss |
| Magnetic Field | oersted |
| Magn Scalar Pot | oersted cm |
| Current Density | A/cm ² |
| Power | W |
| Force | N |

MODEL DATA
 PM_frame_try3_40cm.op3
 Magnetostatic (TOSCA)
 Nonlinear materials
 Simulation No 3 of 4
 6404240 elements
 8876754 nodes
 8 conductors
 Nodally interpolated fields
 Activated in global coordinates
 Reflection in XY plane (Z field=0)

Field Point Local Coordinates
 Local = Global



Figure 1. There are two coils on each piece of steel. The inner coils are connected to form a quadrupole. The outer coils are connected in pairs to produce horizontal and vertical correctors. There is a 3.7 mm gap between them for a 3 mm plate of copper, Kapton insulated, with water tubes along the length in the corners of the assembly to conductively cool the coils. Steel has 2.5 cm section and is 40 cm long. Steel square inner dimension 26.66 cm, 10.5". Clear bore inside the coils 20 cm square with #14 square wire; this will change slightly with #11 square.

8/Aug/2022 06:42:41

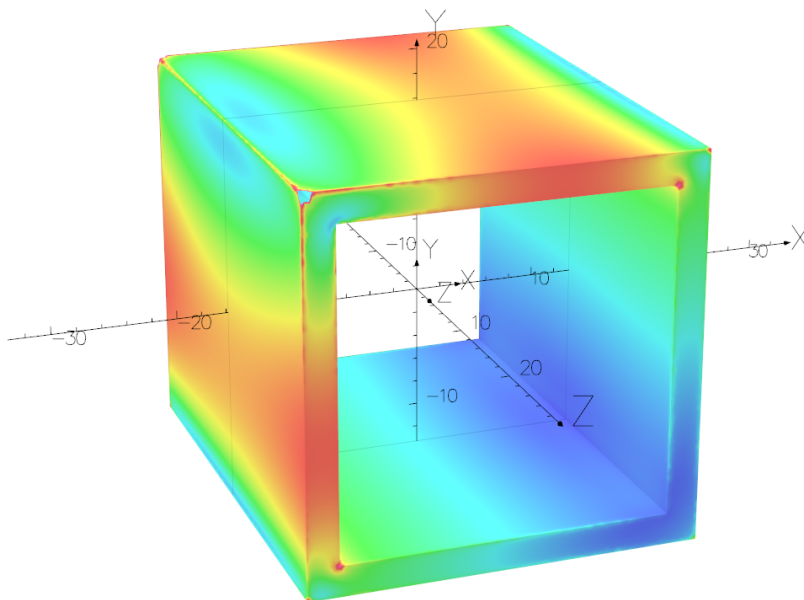
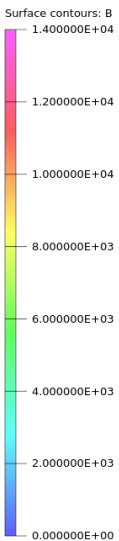

| UNITS | |
|-------------------|-------------------|
| Length | cm |
| Magn Flux Density | gauss |
| Magnetic Field | oersted |
| Magn Scalar Pot | oersted cm |
| Current Density | A/cm ² |
| Power | W |
| Force | N |

MODEL DATA
 PM_frame_try3_40cm.op3
 Magnetostatic (TOSCA)
 Nonlinear materials
 Simulation No 3 of 4
 6404240 elements
 8876754 nodes
 8 conductors
 Nodally interpolated fields
 Activated in global coordinates
 Reflection in XY plane (Z field=0)

Field Point Local Coordinates
 Local = Global



Figure 2. Field on the surface of the steel with 6578 AT in quad coils and 6420 AT in dipole coils. Resulting fields exceed the requirements on page one. It is unlikely that all coils will be energized at once, much less at maximum, but the steel should be sized to allow this. It is expected that only one of the dipoles will be powered in each unit, corresponding to the type of gradient provided in the permanent magnet: horizontal correction for focusing, vertical correction for defocusing.

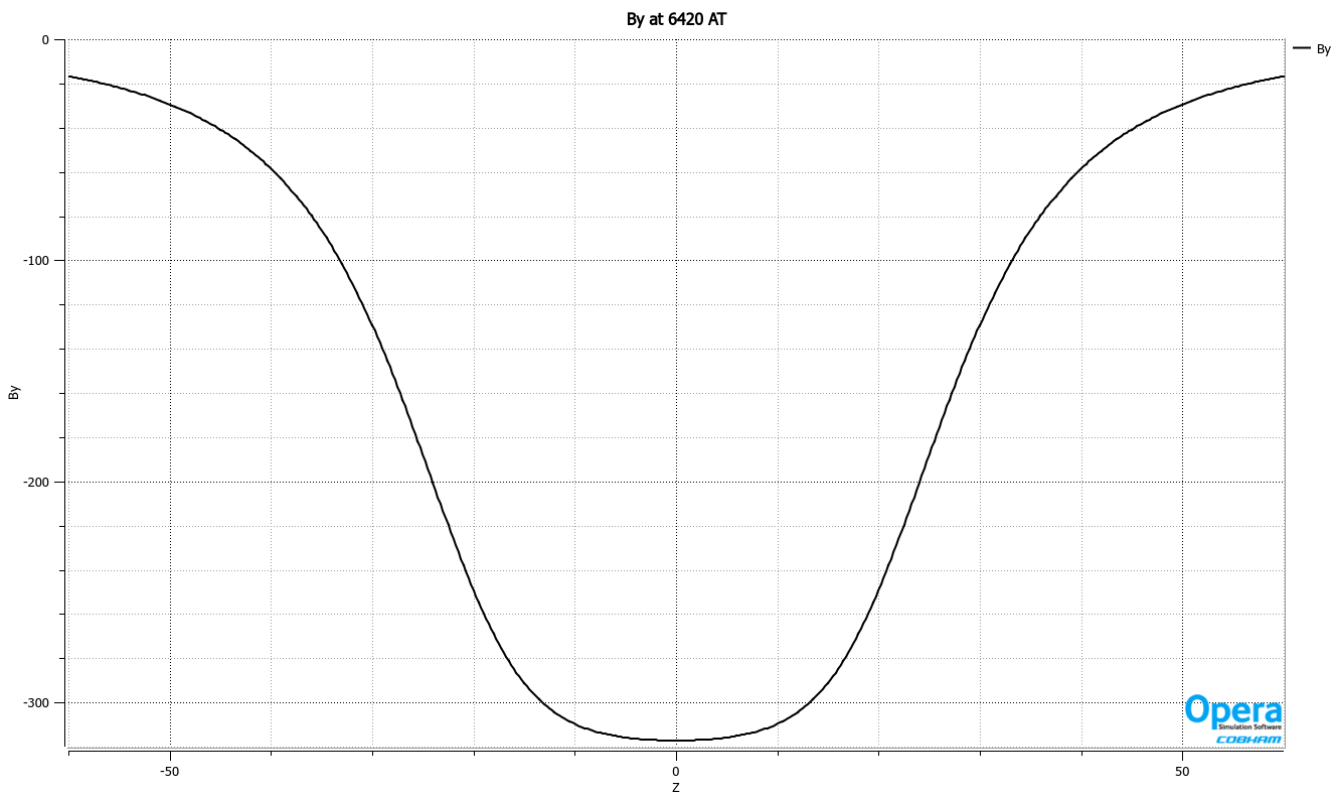

Figure 3. $B_y(z)$ for the dipole which moves beam horizontally. Just under 320 G is available, in agreement with the specification on page one.

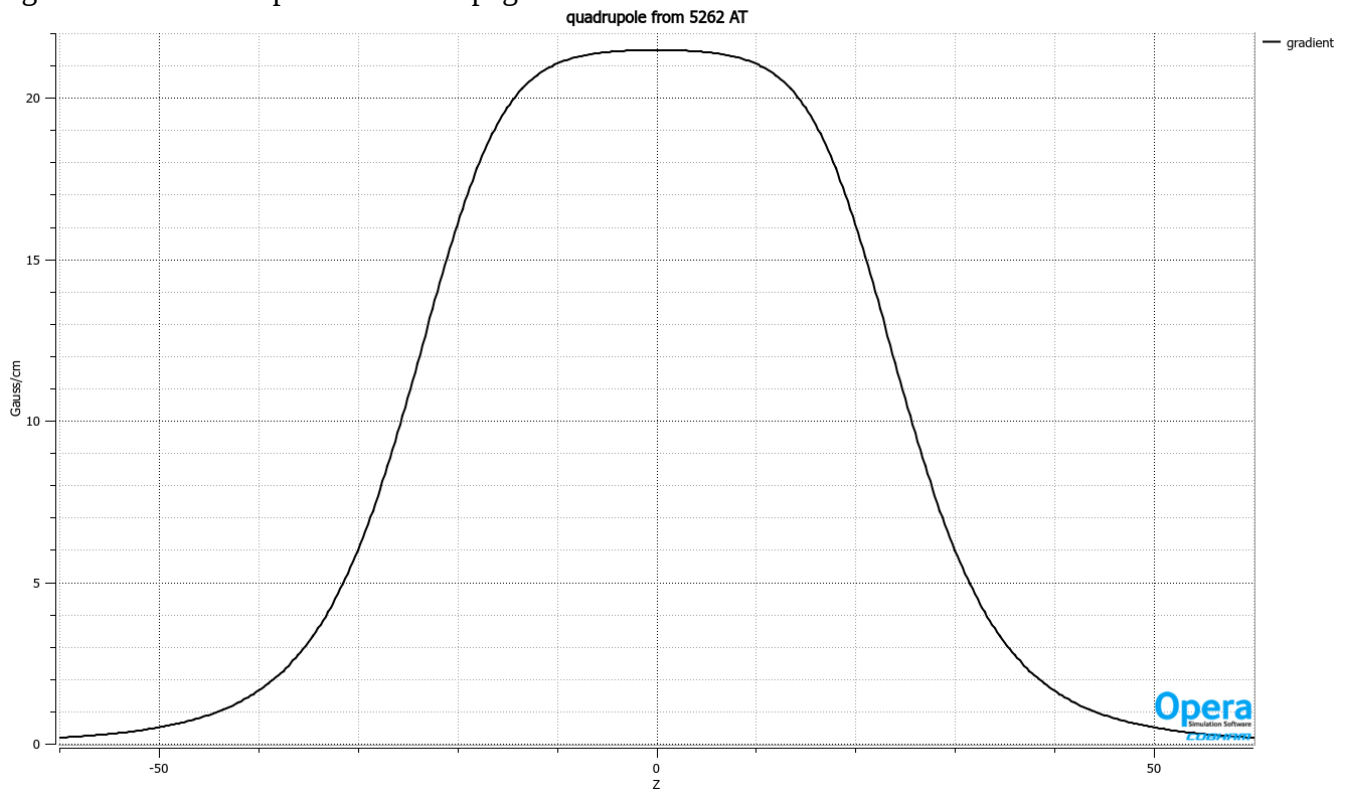

Figure 4. Gradient provided by the quadrupole coil at 5262 AT. Peak is 215 mT/m, 1.2x the request of 3×60 mT/m on page one.

Conductor

The models were built assuming #14 square copper. For the quadrupole, 8 layers by 128 turns, resulting section 1.43 cm by 23 cm. For the dipoles, 6 layers by 110 turns, resulting section 1.07 cm by 20 cm. While the resulting power draws were 700 W and 900 W respectively, the peak voltage was about twice the capability of the existing 75 V/ 20 A trim supplies. #11 square, which has half the resistance of #14 square, was therefore checked. For the quadrupole, 7 layers at 104 turns will result in a coil section 1.54 cm by 23 cm. For the dipole, 5 layers at 90 turns will result in a section 1.1 cm by 20 cm. These will roughly double the current and halve the voltage required, placing the coils within the capabilities of the existing supplies. Compatibility is good. The clear bore will decrease from the 20.5 cm in the present model but will remain greater than the 20 cm square chosen as the goal.

The outside coil area on each piece of steel is about 20 x 45 cm or 900 cm². At 400 W/side, power dissipated is under 0.5 W/cm². It may be that convection will suffice but the 3 mm of water-cooled copper between the two coils is a prudent addition for this level of study. That copper might be added only on the inside of the assembly as maintaining the temperature of the permanent magnets is more critical than the outside temperature of this assembly. (Has anyone looked at the effect of our 35 C LCW on the permanent magnet fields?)

Conclusions

A conceptual design for the correctors needed for the FFA arc has been completed and taken to the level needed for a first cost estimate. Approximately 200 of these assemblies will be needed for each FFA arc. Total assemblies ~400 and total power supplies ~800. Another design pass is required after the lattice including splitters, and the physical layout including mounting/alignment are developed further.