

Title		
<b>CDC Electronics Assembly</b>		
Size	Number	Revision
A		
Date:	8/13/2008	Sheet 3 of 3
File:	C:\ALTIUM\CDC\CDC_Assembly3.SchDoc Drawn By: <b>F.J. Barbosa</b>	

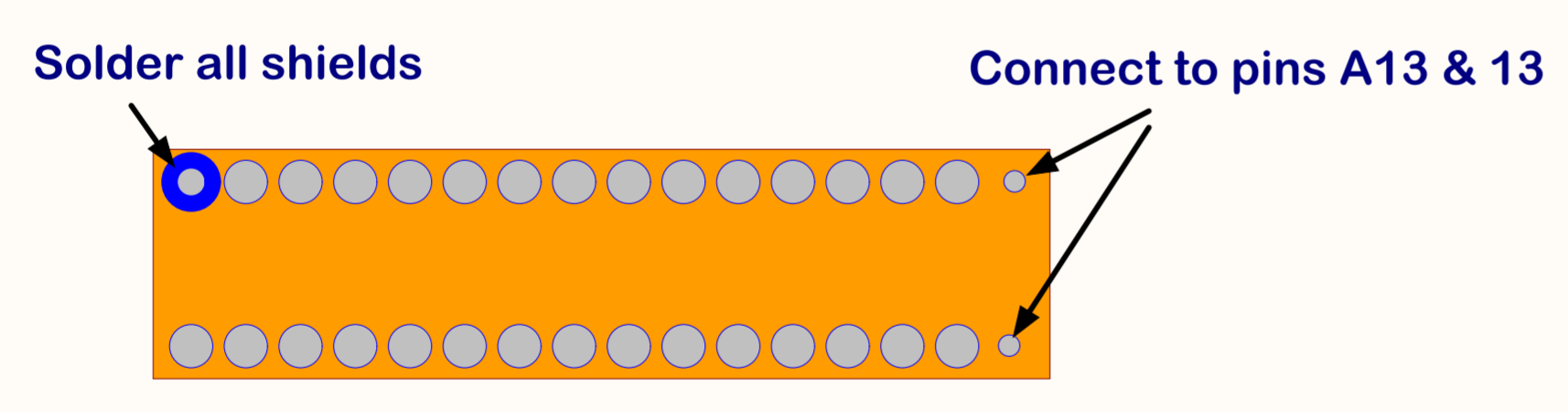

Copper Shield Plate (1/8" thick)

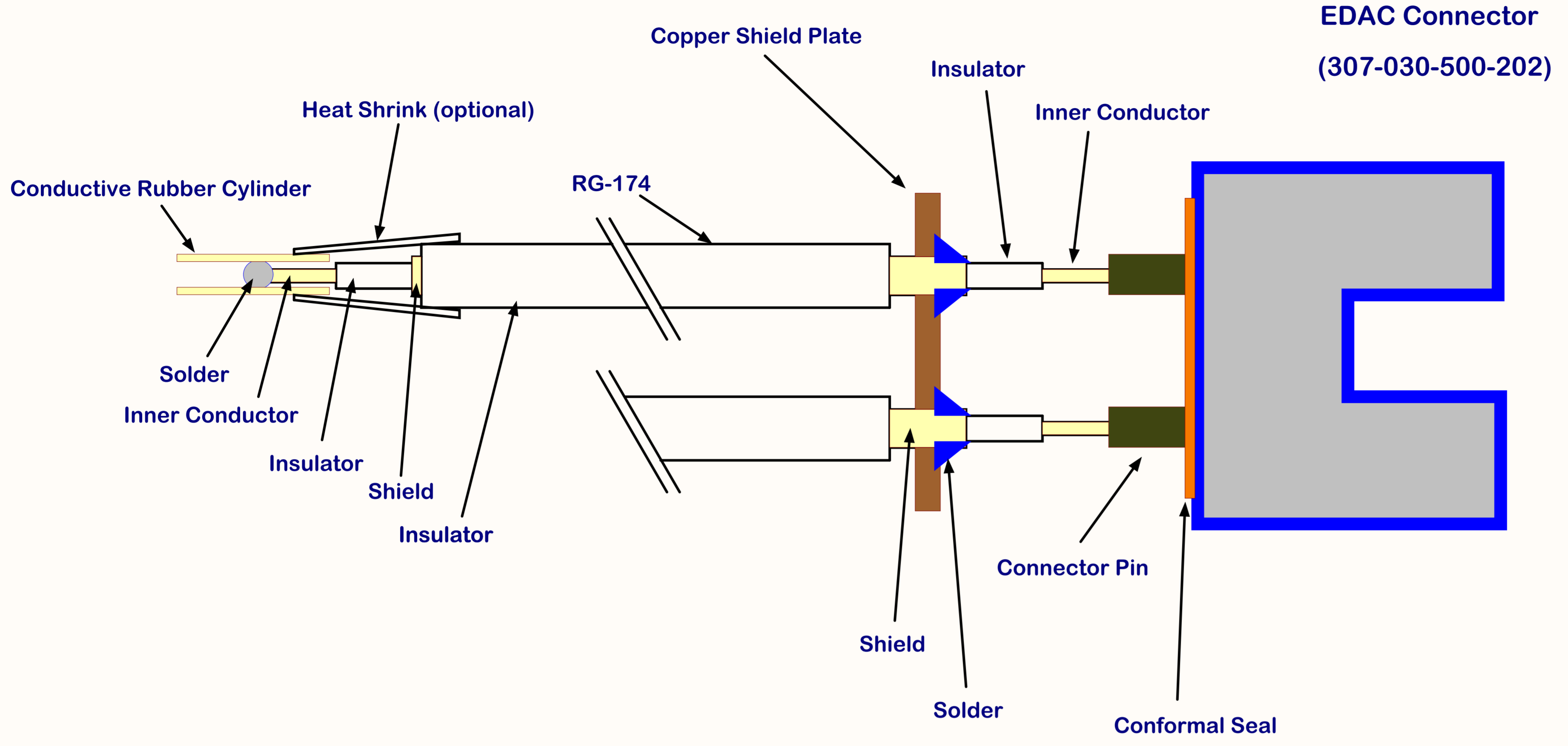
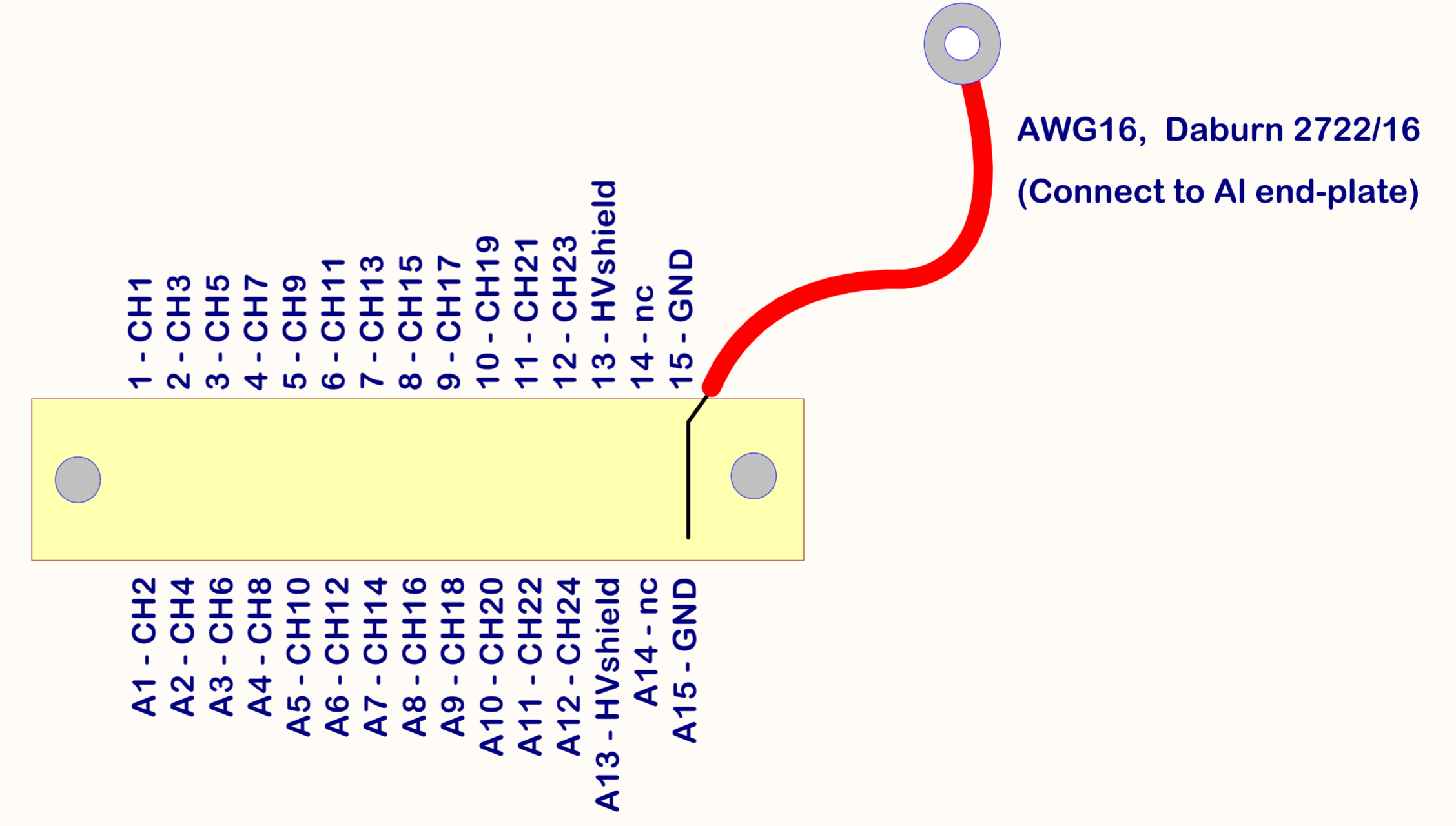

Connector Pinout (Pin Side View)

Title		
<b>CDC Electronics Assembly</b>		
Size	Number	Revision
A		
Date:	8/13/2008	Sheet 1 of 3
File:	C:\ALTIUM\CDC\CDC_Assembly1.SchDoc	Drawn By: F.J. Barbosa

EDAC Connector  
(307-030-500-202)

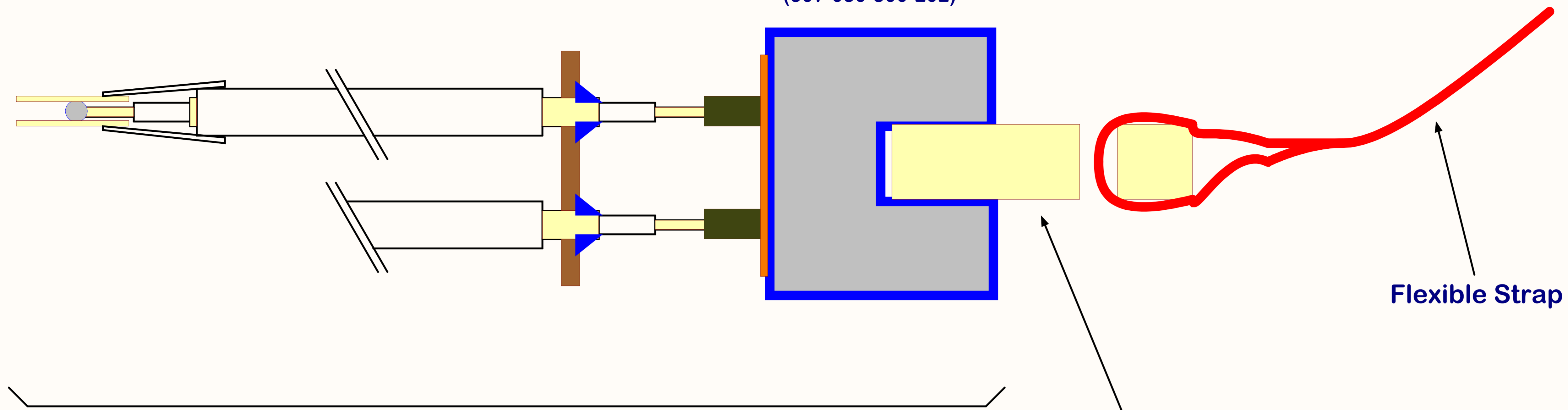

Connector Assembly

Assembly PCB ("dummy")

Flexible Strap

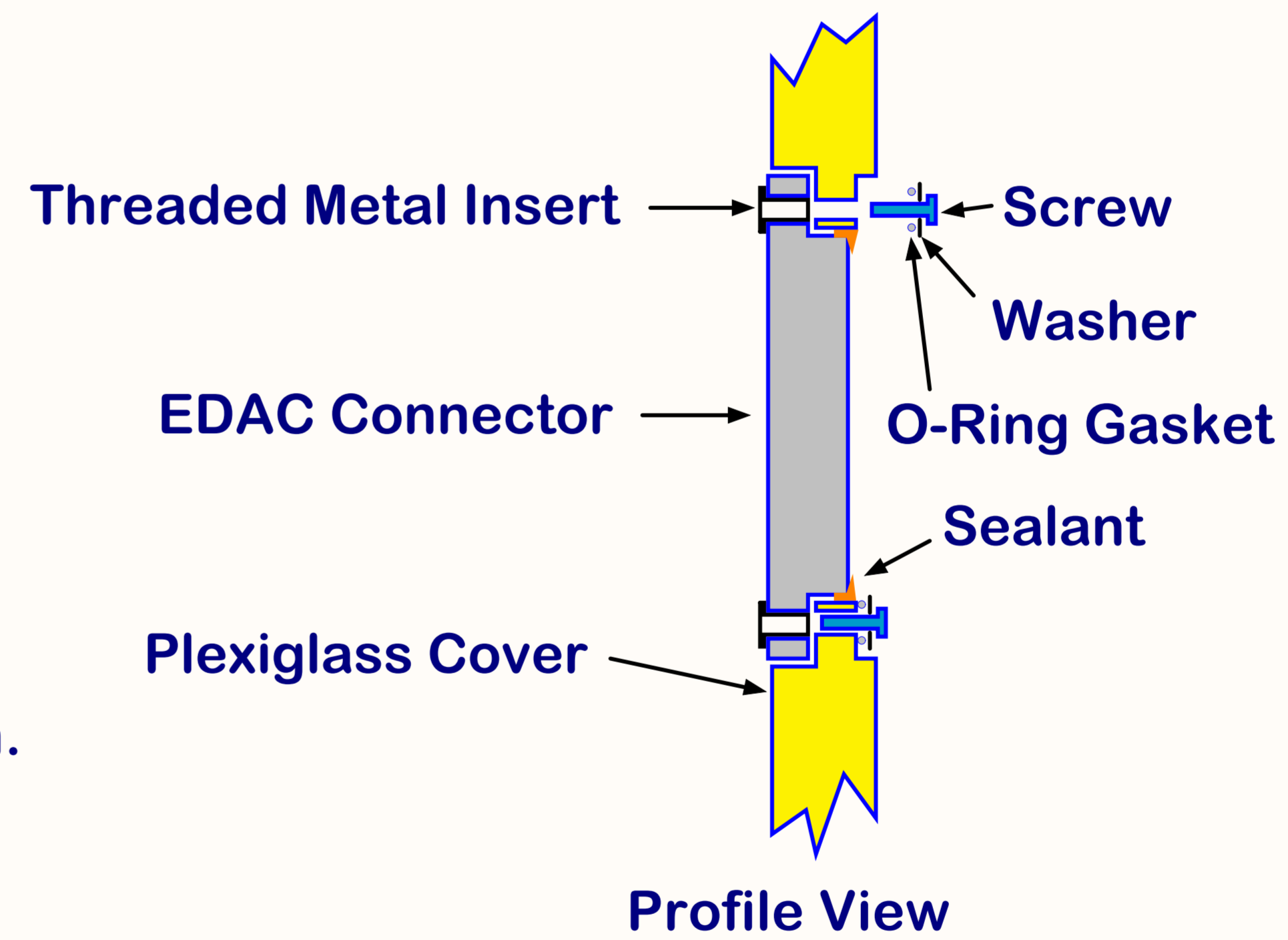

Profile View

**NOTE:** Connector assemblies must be cleaned properly before installation.

**Assembly Procedure:**

1. Connect the cables from a connector assemblies to their respective straws.
2. Step 1 can be performed with the CDC horizontal or vertical.
3. Feed the straps through the plexiglass cover holes corresponding to the connector positions.
4. Slide the plexiglass cover towards the endplate.
5. Secure connectors to the plexiglass cover with screws, O-ring gaskets and washers.
6. Rotate CDC vertical and seal around connectors with non-silicone sealant.

Title		
<b>CDC Electronics Assembly</b>		
Size	Number	Revision
A		
Date:	8/13/2008	Sheet 2 of 3
File:	C:\ALTIUM\CDC\CDC_Assembly2.SchDo	Drawn By: F.J. Barbosa